

BF-WI-ENG-013/02

IMPORTANT

Issue 1

Check the Intranet to ensure you are using the latest issue of this Form**Amphenol**

MANUFACTURING INSTRUCTION

Number: 123GB-0842

Issue: 1

Page:

Print test box



1 of 9

Products are sold subject to Amphenol's conditions of sale ("the standard conditions"). All specifications and statements contained herein are believed to be correct at the time a printing, but no representation or warranty, express or implied is, given as to any specification or statement contained herein. Product specifications including performance characteristics are typical only and subject to deviation. Specifications are also subject to change without notice. Users should not assume that all safety measures are indicated or that measures may not be required. No representation or warranty, express or implied, is given that any use of products (including any stated or suggested use) does not infringe any patent, registered design or other third party rights and no stated or suggested use of products can be taken to recommend any such infringement.

**** FOLLOW ALL LOCAL HEALTH AND SAFETY POLICIES ****

**123GB-0842 refers to product part number family
WPTV-07XXXX-XXX-XXXX**

WPTV-07 style = Jam Nut Receptacle.

Key Points with reference to this assembly.

1. Refer to the catalogue for part number breakdown.
2. This document covers different accessory types.
See the next page for variant types and reference views.
3. The backshell of the connectors are supplied loose.
These must be terminated by the user prior to use.

List of Documents used in this spec

123GB-0845	Torque settings & tools
123GB-0846	Crimp settings & tools

List of Tools used in this MI

Torque tools	See document 123GB-0845
Crimp tools	See document 123GB-0846

Release / Changes:	DRAFT A	Issue 1				
Originator:	MSS	JT				
Date:	26/02/14	24/7/14				

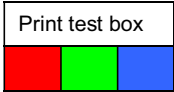

This document and its contents remain the property of Amphenol Ltd. This document contains confidential proprietary information, and shall not be copied, disclosed, reproduced or used for any other purpose; unless written permission is granted by Amphenol Ltd. Amphenol Ltd retains the right to request the prompt return of this document.

BF-WI-ENG-013/02	<u>IMPORTANT</u>
Issue 1	Check the Intranet to ensure you are using the latest issue of this Form

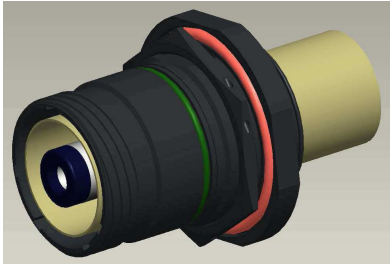
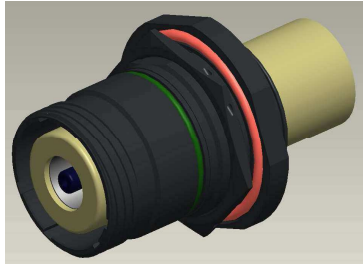
<h1>Amphenol</h1>	Number: 123GB-0842 Issue: 1 Page:	Print test box  2 of 9
MANUFACTURING INSTRUCTION		

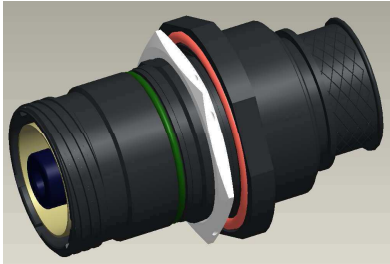
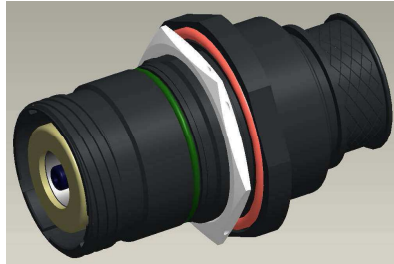
Reference views.	
WPTV-07XXXX-XXX-XPXA Pin variant  <p><i>General assembled view/s of the assembly, for reference.</i></p>	WPTV-07XXXX-XXX-XSXA Socket variant  <p><i>General assembled view/s of the assembly, for reference.</i></p>

Reference views.	
WPTV-07XXXX-XXX-XPXB Pin variant  <p><i>General assembled view/s of the assembly, for reference.</i></p>	WPTV-07XXXX-XXX-XSXB Socket variant  <p><i>General assembled view/s of the assembly, for reference.</i></p>

Reference views.	
WPTV-07XXXX-XXX-XPXC Pin variant  <p><i>General assembled view/s of the assembly, for reference.</i></p>	WPTV-07XXXX-XXX-XSXC Socket variant  <p><i>General assembled view/s of the assembly, for reference.</i></p>

Release / Changes:	DRAFT A	Issue 1				
Originator:	MSS	JT				
Date:	26/02/14	24/7/14				

This document and its contents remain the property of Amphenol Ltd. This document contains confidential proprietary information, and shall not be copied, disclosed, reproduced or used for any other purpose; unless written permission is granted by Amphenol Ltd. Amphenol Ltd retains the right to request the prompt return of this document.

BF-WI-ENG-013/02
Issue 1

IMPORTANT

Check the Intranet to ensure you are using the latest issue of this Form

Amphenol

MANUFACTURING INSTRUCTION

Number: 123GB-0842

Issue: 1

Page:

Print test box

3 of 9

OP 10. WPTV-07XXXX-XXX-1XXA variant.
(also WPTV-07XXXX-XXX-6XXA, WPTV-07XXXX-XXX-7XXA, WPTV-07XXXX-XXX-8XXA variants).

Main Steps

- 1). Unpack the connector. Remove the plain backshell, rear insulator & contact assembly, and retain for assembly later.
 - 1a). *O-rings must be fitted as per illustrations (including suitable grease) for connector to seal.*
- 2). Feed the plain backshell then insulator onto the prepared cable and terminate the contact as per document 123GB-0846.
- 3). Assemble the terminated contact into the front insulator in the receptacle shell.
- 4). Assemble the rear insulator over the rear of the contact assembly.
- 5). Secure the plain backshell as per document 123GB-0845.

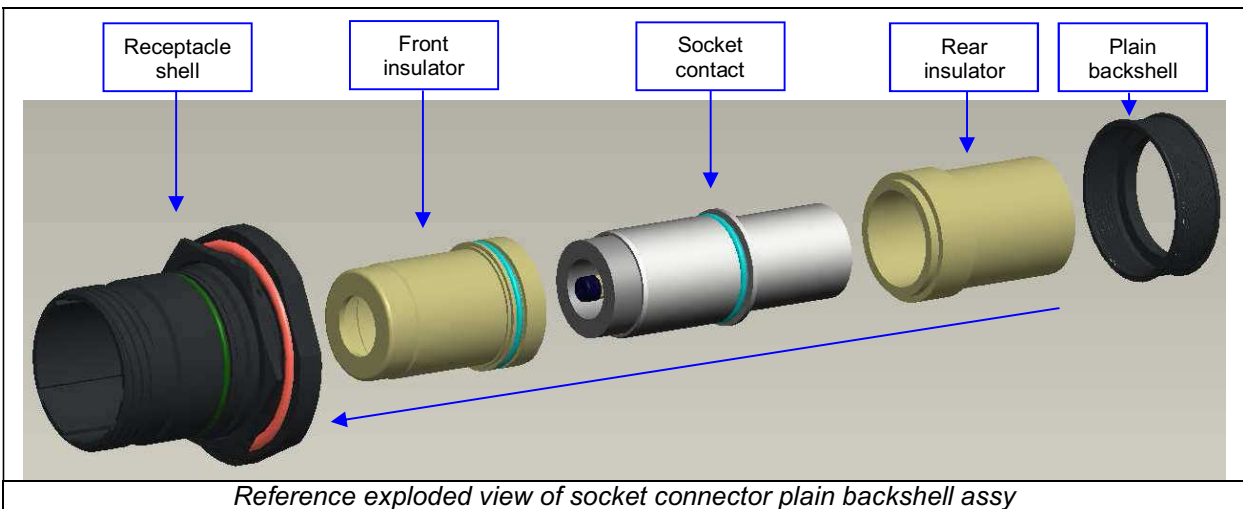
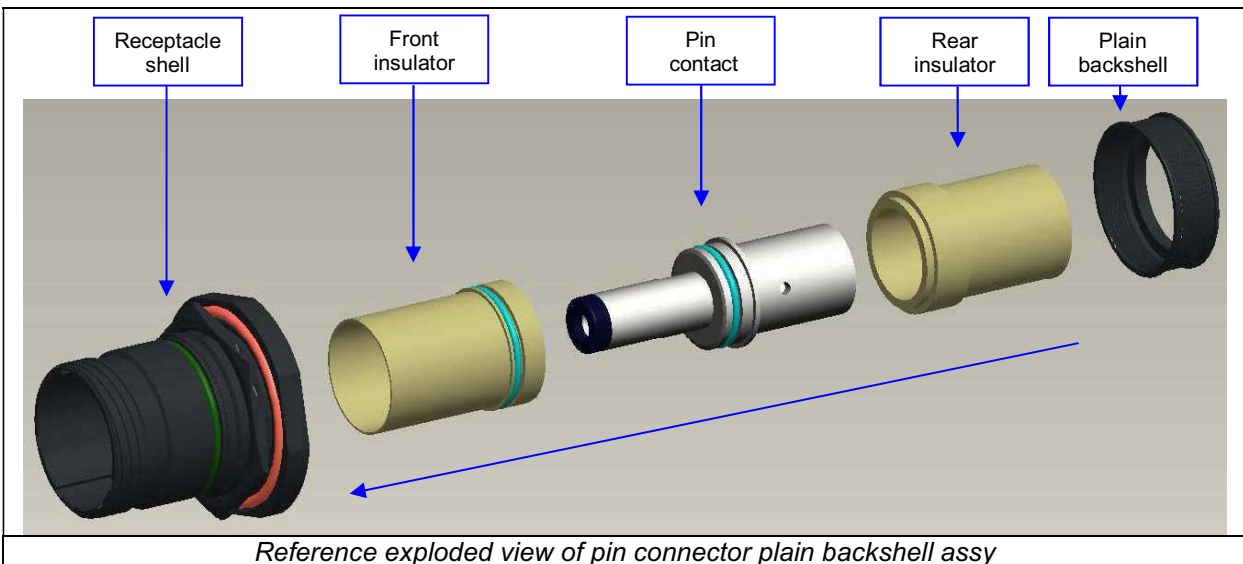

Release / Changes:	DRAFT A	Issue 1				
Originator:	MSS	JT				
Date:	26/02/14	24/7/14				

This document and its contents remain the property of Amphenol Ltd. This document contains confidential proprietary information, and shall not be copied, disclosed, reproduced or used for any other purpose; unless written permission is granted by Amphenol Ltd. Amphenol Ltd retains the right to request the prompt return of this document.

BF-WI-ENG-013/02

IMPORTANT

Issue 1

Check the Intranet to ensure you are using the latest issue of this Form

Amphenol

MANUFACTURING INSTRUCTION

Number: 123GB-0842

Issue: 1

Page:

Print test box

4 of 9

OP 10. WPTV-07XXXX-XXX-2XXA variant.

Main Steps

- 1). Unpack the connector. Remove the plain backshell, rear insulator & contact assembly, and retain for assembly later.
 - 1a). O-rings must be fitted as per illustrations (including suitable grease) for connector to seal.
- 2). Feed the plain backshell then insulator onto the prepared cable and terminate the contact as per document 123GB-0846.
- 3). Assemble the terminated contact into the front insulator in the receptacle shell.
- 4). Assemble the rear insulator over the rear of the contact assembly.
- 5). Secure the plain backshell as per document 123GB-0845.

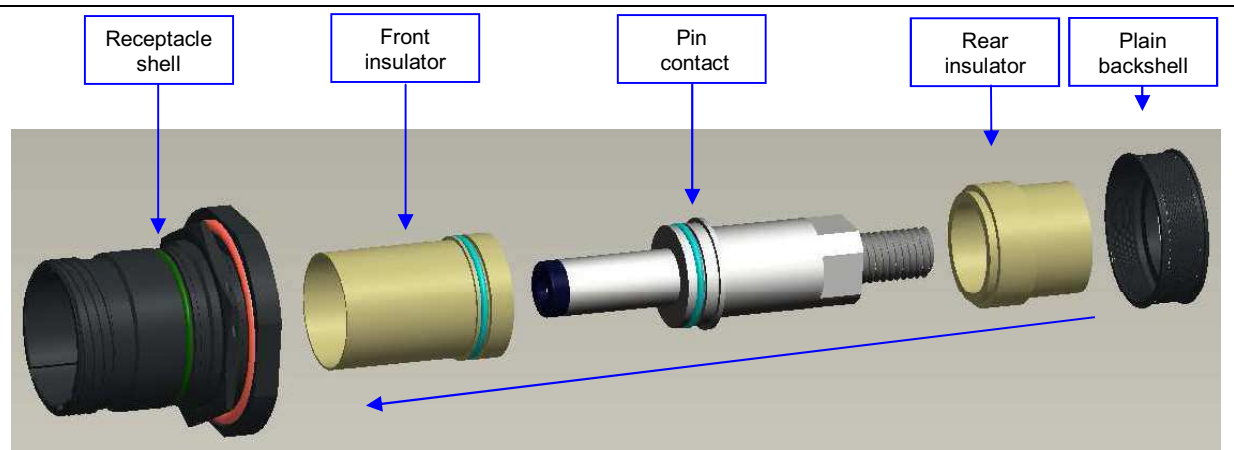

Reference exploded view of pin connector plain backshell assy

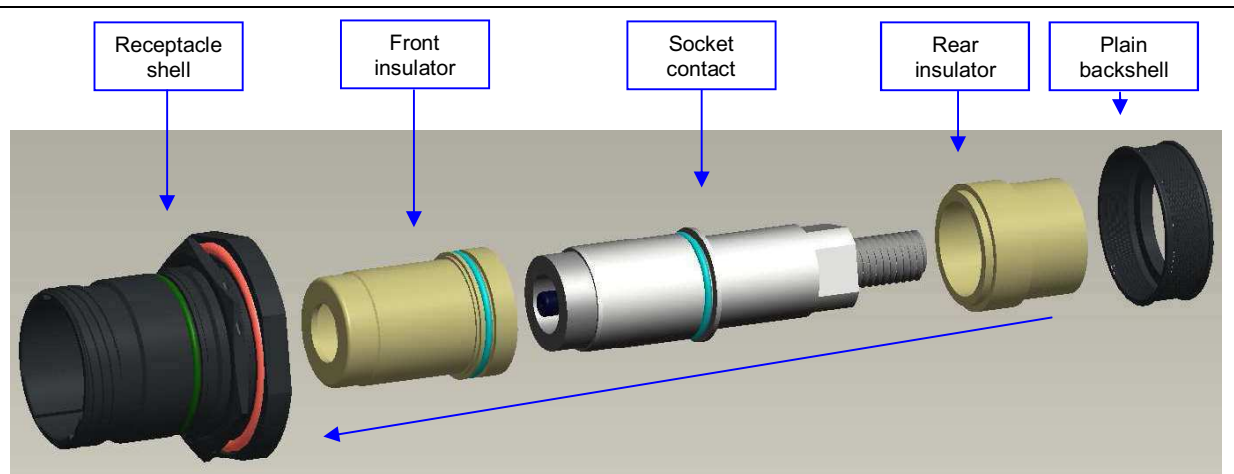

Reference exploded view of socket connector plain backshell assy

Release / Changes:	DRAFT A	Issue 1				
Originator:	MSS	JT				
Date:	26/02/14	24/7/14				

This document and its contents remain the property of Amphenol Ltd. This document contains confidential proprietary information, and shall not be copied, disclosed, reproduced or used for any other purpose; unless written permission is granted by Amphenol Ltd. Amphenol Ltd retains the right to request the prompt return of this document.

BF-WI-ENG-013/02
Issue 1

IMPORTANT

Check the Intranet to ensure you are using the latest issue of this Form

Amphenol

MANUFACTURING INSTRUCTION

Number: 123GB-0842

Issue: 1

Page:

Print test box

5 of 9

OP 10.	WPTV-07XXXX-XXX-3XXA variant.
Main Steps	
<p>1). Unpack the connector. Remove the plain backshell, rear insulator & contact assembly, and retain for assembly later.</p> <p style="margin-left: 20px;">1a). O-rings must be fitted as per illustrations (including suitable grease) for connector to seal.</p> <p>2). Feed the plain backshell then insulator onto the prepared cable and terminate the contact as per document 123GB-0846.</p> <p>3). Assemble the terminated contact into the front insulator in the receptacle shell.</p> <p>4). Assemble the rear insulator over the rear of the contact assembly.</p> <p>5). Secure the plain backshell as per document 123GB-0845.</p>	

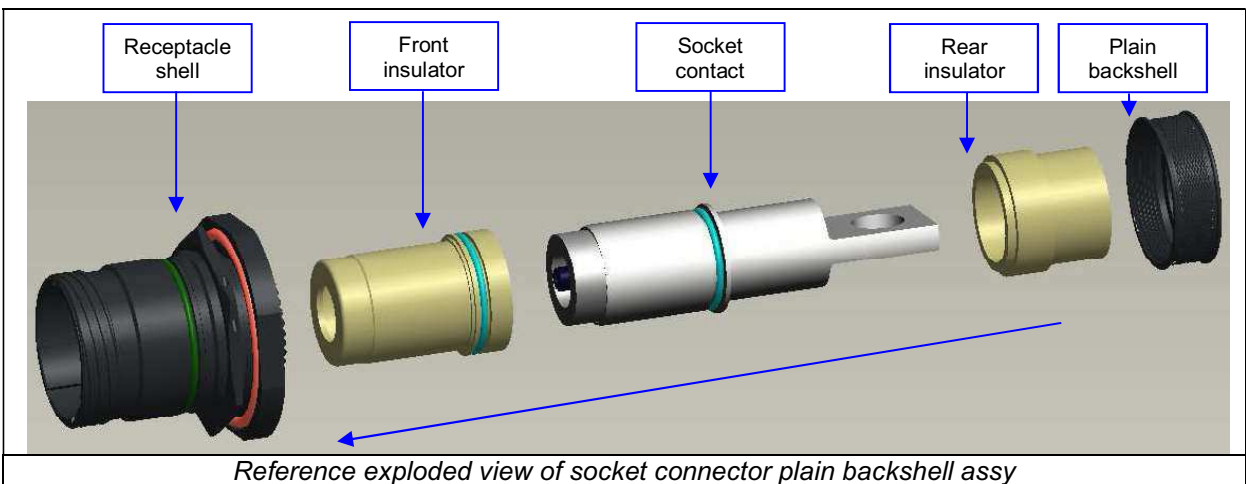
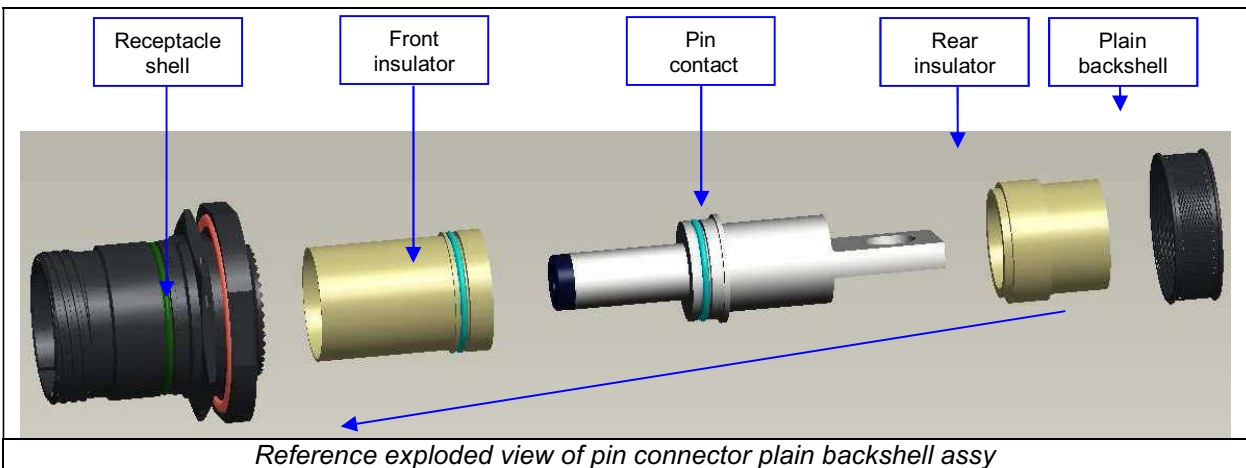

Release / Changes:	DRAFT A	Issue 1				
Originator:	MSS	JT				
Date:	26/02/14	24/7/14				

This document and its contents remain the property of Amphenol Ltd. This document contains confidential proprietary information, and shall not be copied, disclosed, reproduced or used for any other purpose; unless written permission is granted by Amphenol Ltd. Amphenol Ltd retains the right to request the prompt return of this document.

BF-WI-ENG-013/02
Issue 1

IMPORTANT

Check the Intranet to ensure you are using the latest issue of this Form

Amphenol

MANUFACTURING INSTRUCTION

Number: 123GB-0842

Issue: 1

Page:

Print test box

6 of 9

OP 10.	WPTV-07XXXX-XXX-5XXA variant.
Main Steps	
<p>1). Unpack the connector. Remove the plain backshell, rear insulator & contact assembly, and retain for assembly later.</p> <p style="padding-left: 20px;">1a). O-rings must be fitted as per illustrations (including suitable grease) for connector to seal.</p> <p>2). Feed the plain backshell then insulator onto the prepared cable and terminate the contact as per document 123GB-0846.</p> <p>3). Assemble the terminated contact into the front insulator in the receptacle shell.</p> <p>4). Assemble the rear insulator over the rear of the contact assembly.</p> <p>5). Secure the plain backshell as per document 123GB-0845.</p>	

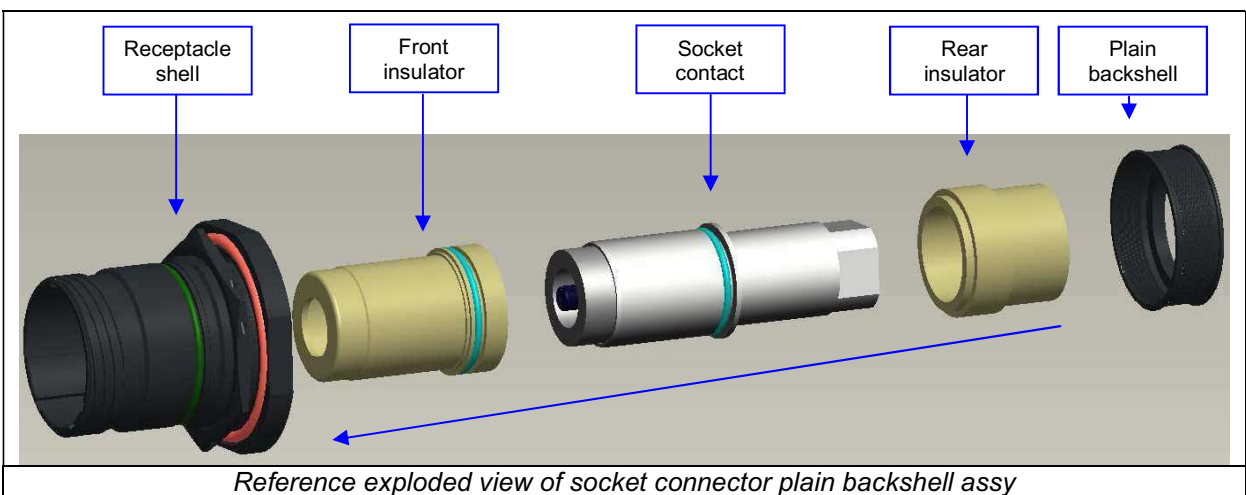
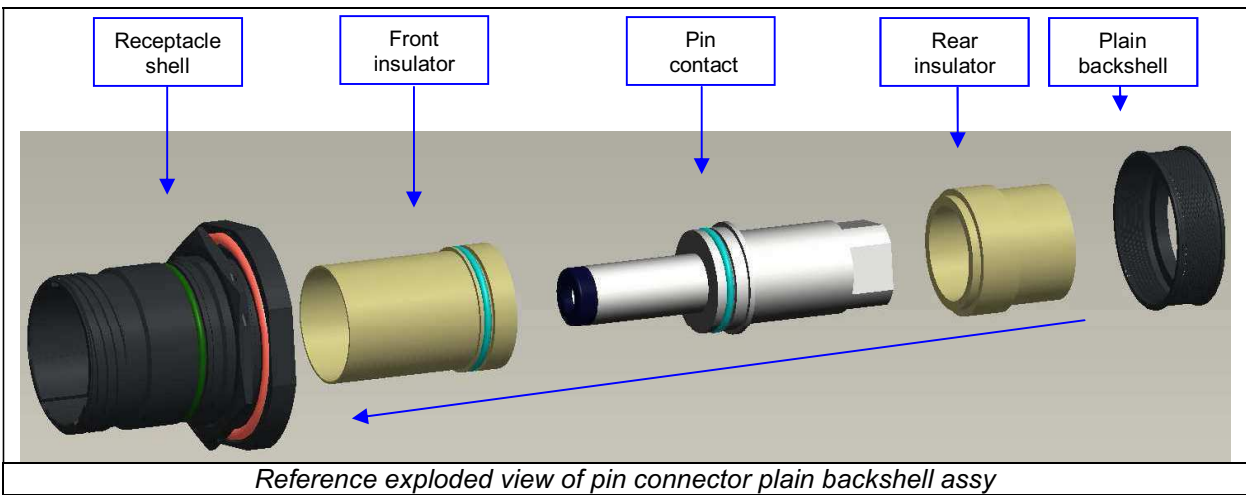

Release / Changes:	DRAFT A	Issue 1				
Originator:	MSS	JT				
Date:	26/02/14	24/7/14				

This document and its contents remain the property of Amphenol Ltd. This document contains confidential proprietary information, and shall not be copied, disclosed, reproduced or used for any other purpose; unless written permission is granted by Amphenol Ltd. Amphenol Ltd retains the right to request the prompt return of this document.

BF-WI-ENG-013/02
Issue 1

IMPORTANT

Check the Intranet to ensure you are using the latest issue of this Form

Amphenol

MANUFACTURING INSTRUCTION

Number: 123GB-0842

Issue: 1

Page:

Print test box

7 of 9

OP 10. **WPTV-07XXXX-XXX-1XXB variant.**
(also WPTV-07XXXX-XXX-6XXB, WPTV-07XXXX-XXX-7XXB, WPTV-07XXXX-XXX-8XXB variants).

Main Steps

- 1). Unpack the connector. Remove the straight backshell, rear insulator & contact assembly, and retain for assembly later.
 - 1a). *O-rings must be fitted as per illustrations (including suitable grease) for connector to seal.*
- 2). Feed the straight backshell then insulator onto the prepared cable and terminate the contact as per document 123GB-0846.
- 3). Assemble the terminated contact into the front insulator in the receptacle shell.
- 4). Assemble the rear insulator over the rear of the contact assembly.
- 5). Secure the straight backshell as per document 123GB-0845.

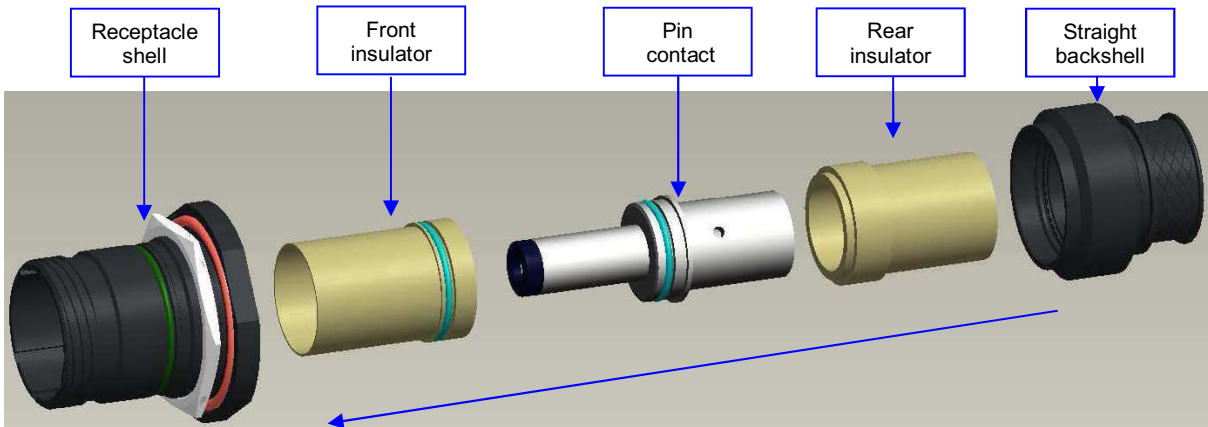

Reference exploded view of pin connector straight backshell assy

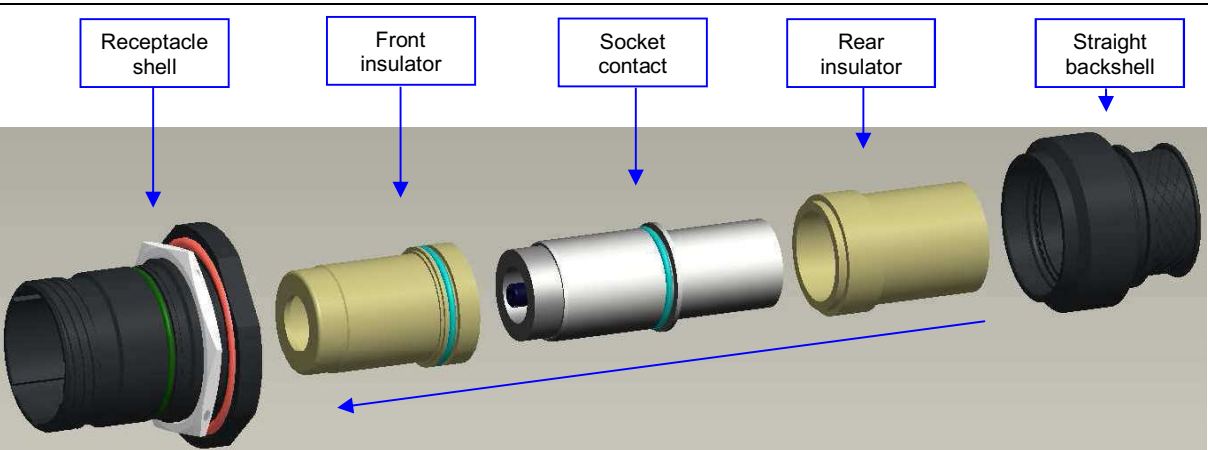

Reference exploded view of socket connector straight backshell assy

Release / Changes:	DRAFT A	Issue 1				
Originator:	MSS	JT				
Date:	26/02/14	24/7/14				

This document and its contents remain the property of Amphenol Ltd. This document contains confidential proprietary information, and shall not be copied, disclosed, reproduced or used for any other purpose; unless written permission is granted by Amphenol Ltd. Amphenol Ltd retains the right to request the prompt return of this document.

BF-WI-ENG-013/02
Issue 1

IMPORTANT

Check the Intranet to ensure you are using the latest issue of this Form

Amphenol

MANUFACTURING INSTRUCTION

Number: 123GB-0842

Issue: 1

Page:

Print test box

8 of 9

OP 10. **WPTV-07XXXX-XXX-1XXC variant.**
(also WPTV-07XXXX-XXX-6XXC, WPTV-07XXXX-XXX-7XXC, WPTV-07XXXX-XXX-8XXC, WPTV-07XXXX-XXX-9XXC variants).

Main Steps

- 1). Unpack the connector. Remove the 90 degree backshell, backshell insulator & crimp contact, and retain for assembly later.
 - 1a). *O-rings must be fitted as per illustrations (including suitable grease) for connector to seal.*
- 2). Terminate the contact as per document 123GB-0846. Place over front of the terminated contact the backshell insulator.
- 3). (1st stage assembly). Assemble the terminated contact & backshell insulator in to the rear of the 90 degree backshell.
- 4). (2nd stage assembly). ***Remember to set the desired main key position prior to performing this step***. Assemble the connector assembly to the backshell.
- 5). Using the tooling & setting as per document 123GB-0845. Secure the connector assembly to the backshell via the terminated contact.

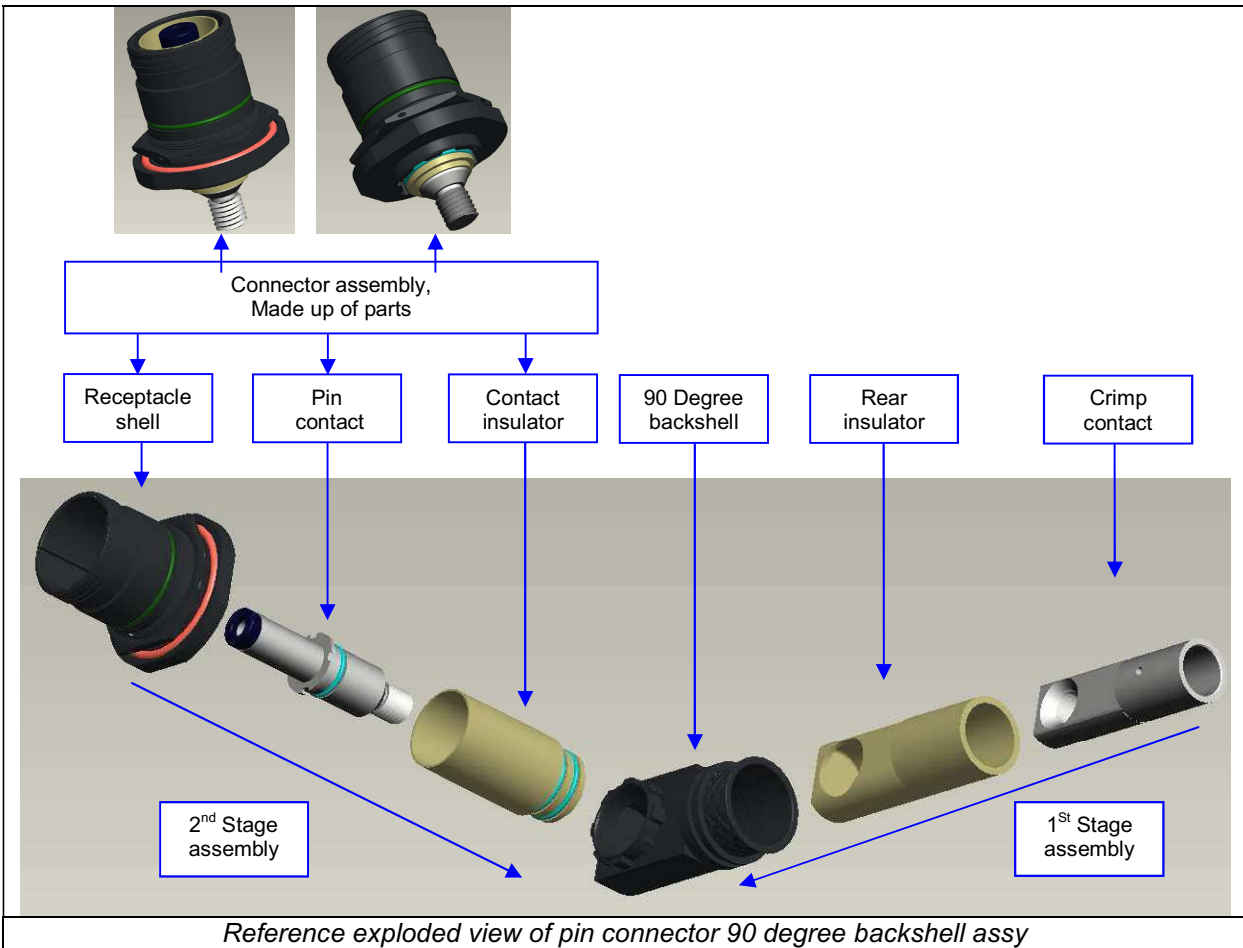

Release / Changes:	DRAFT A	Issue 1				
Originator:	MSS	JT				
Date:	26/02/14	24/7/14				

This document and its contents remain the property of Amphenol Ltd. This document contains confidential proprietary information, and shall not be copied, disclosed, reproduced or used for any other purpose; unless written permission is granted by Amphenol Ltd. Amphenol Ltd retains the right to request the prompt return of this document.

BF-WI-ENG-013/02
Issue 1

IMPORTANT

Check the Intranet to ensure you are using the latest issue of this Form

Amphenol

Number: 123GB-0842

Issue: 1

Page:

Print test box

9 of 9

MANUFACTURING INSTRUCTION

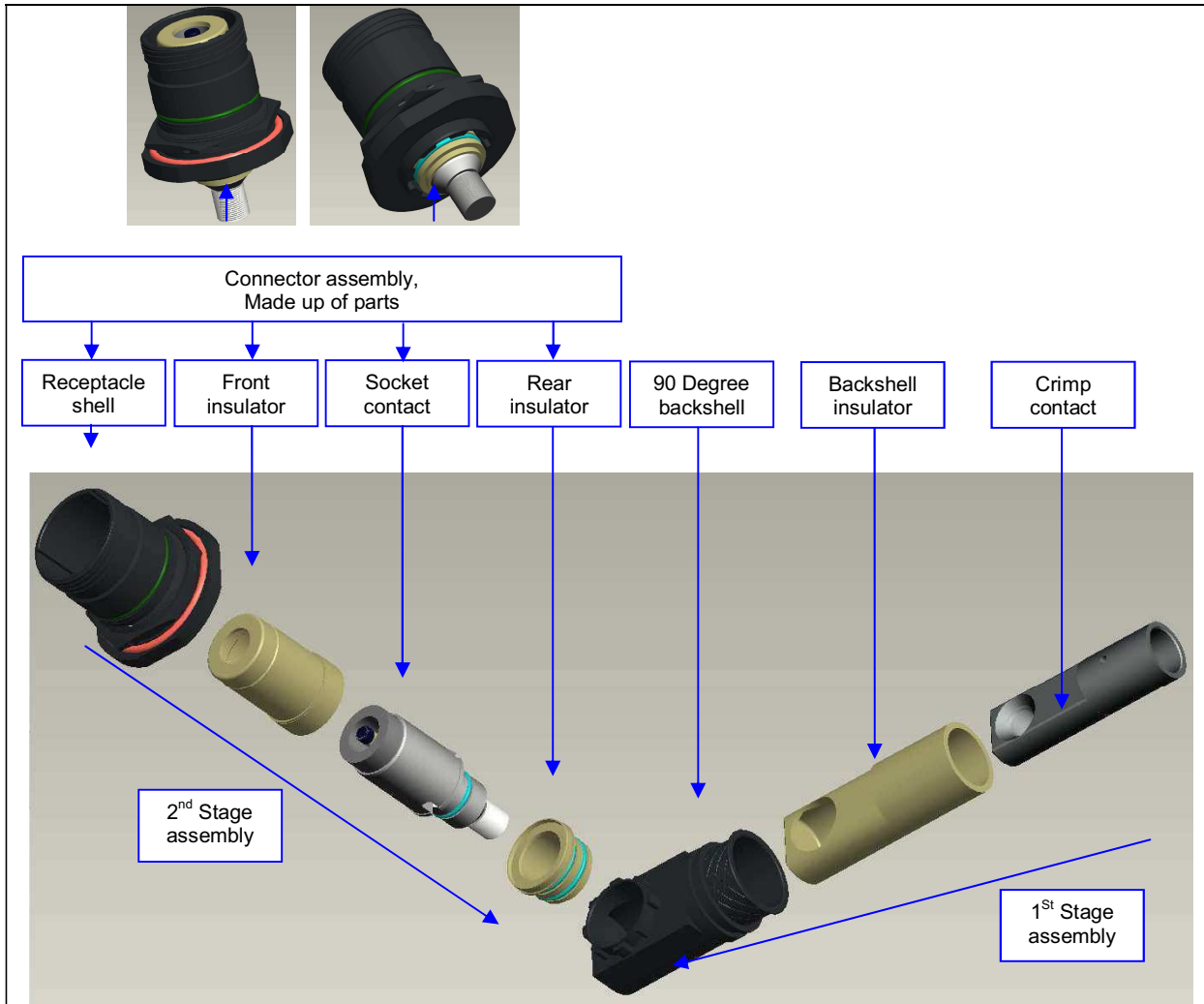

Reference exploded view of socket connector 90 degree backshell assy

OP 20.	Inspection.	
Main Steps	Key Points	Sketch / Picture
Inspect the connector assembly.	Check for any damage that would effect functionally of the product.	

Release / Changes:	DRAFT A	Issue 1				
Originator:	MSS	JT				
Date:	26/02/14	24/7/14				

This document and its contents remain the property of Amphenol Ltd. This document contains confidential proprietary information, and shall not be copied, disclosed, reproduced or used for any other purpose; unless written permission is granted by Amphenol Ltd. Amphenol Ltd retains the right to request the prompt return of this document.