

Issue No.	Eng. Ref. No.	REVISIONS	Date	App. By
6	B302	90° FORM- FIGURE & NOTE ADDED	25/07/18	SPK
7	B321	TABLE-A MODIFIED	19/06/19	SPK

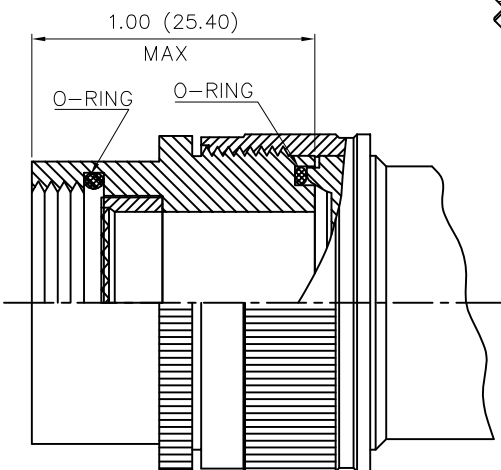

STYLE-2 : MODIFICATION

**PART NUMBERING SYSTEM :-**

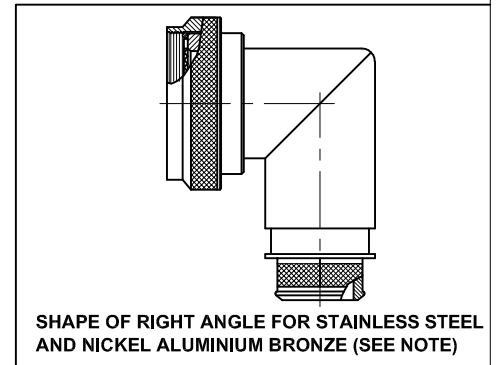
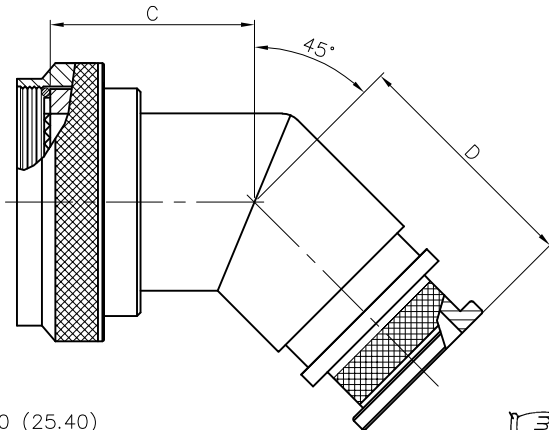
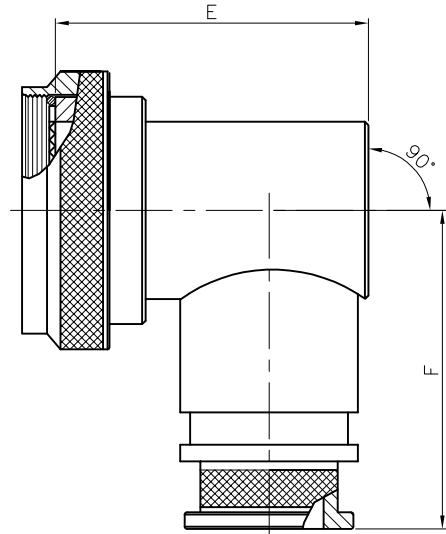
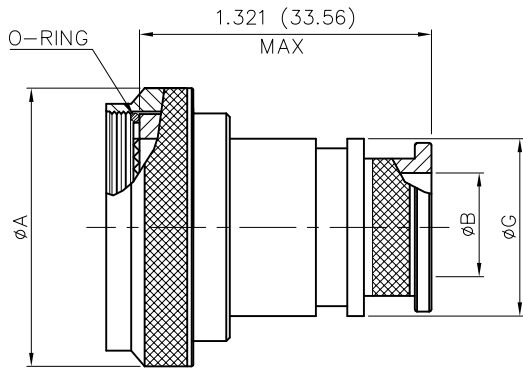
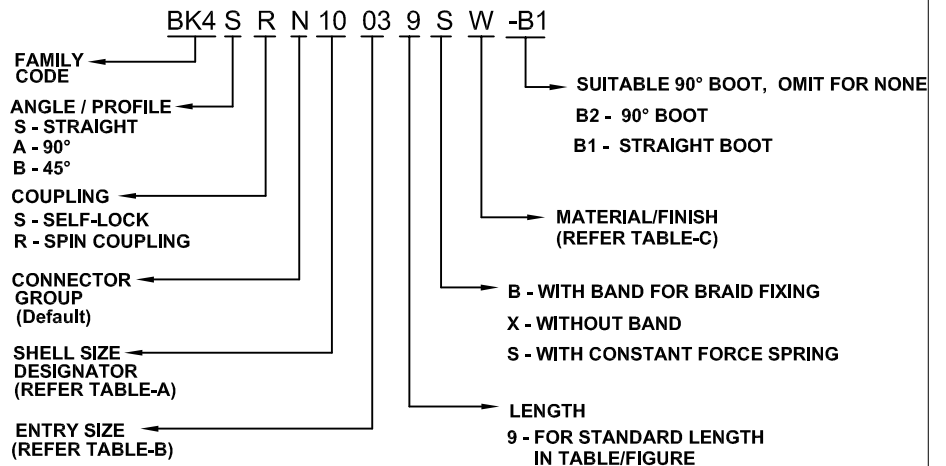

**Amphenol**  
AIPL

**TITLE**  
**BAND LOCK ADAPTER (BK4)**  
FOR CONNECTORS BS9522 F0017/PATT105,  
BS9522 N0001/PATT603, BS9522 F0090/PATT 608

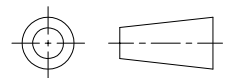

All Dimensions are in  
INCHES(MM)

**STANDARD**

	Name	Date
Drawn by	<i>Santhosh</i>	15/10/09
Checked by	KSC	17/08/12
App.by	SPK	17/08/12

Dwg. Size  
**A4**

Dwg.No.	<b>PSTDBS249</b>
Doc. No.:	QF-DEV-76
REV. NO. :	02
Sheet	1 OF 2

